

1.0 Wide Exit One Way Gate Mounting Dimensions

Mounting Height: Mount 4" x 4" square tube 72" from floor to bottom of tube. Use Mount Clamp Kit based on post size:

- 3G07130-WE One Way Gate Mount Clamp Kit-2½"
- 3G07135-WE One Way Gate Mount Clamp Kit-3"
- 3G07140 WE One Way Gate Mount Clamp-4"

Spacing: Maximum spacing between post and gate pipe is 11". Use Spacer Tube Kit (3G07115) to reduce openings to 11" or less.

Note: Use spacer tube kits as require to maintain proper gate spacing.

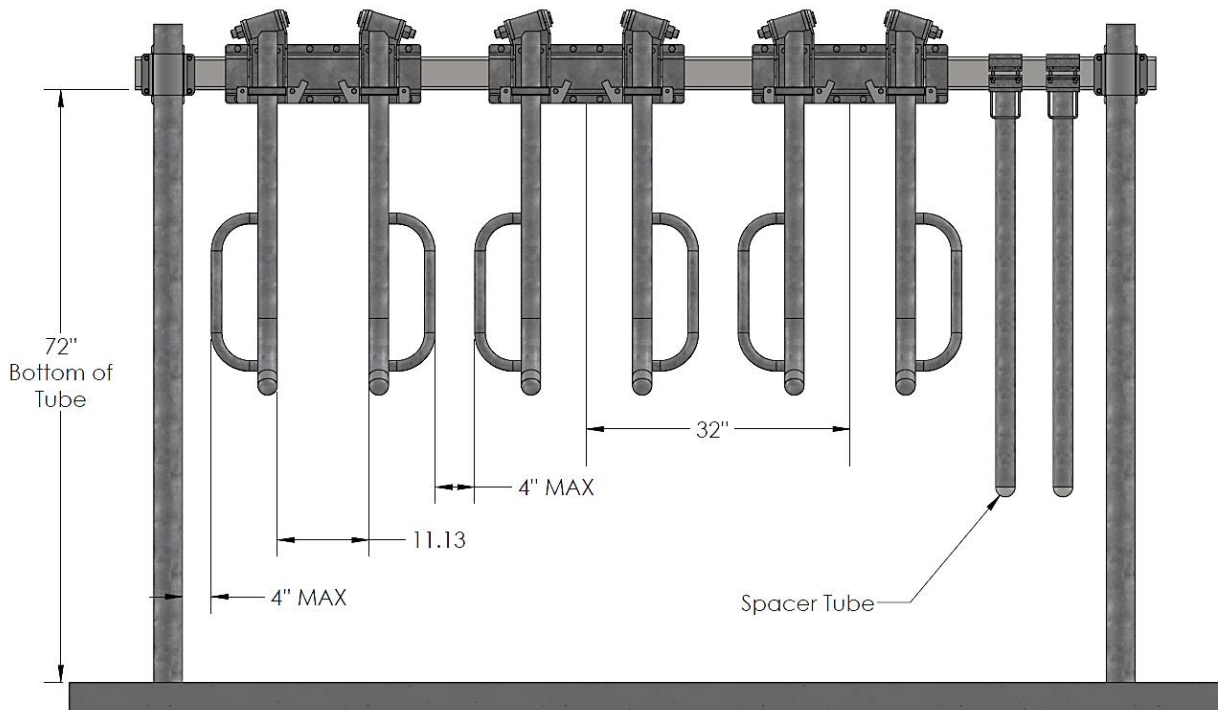
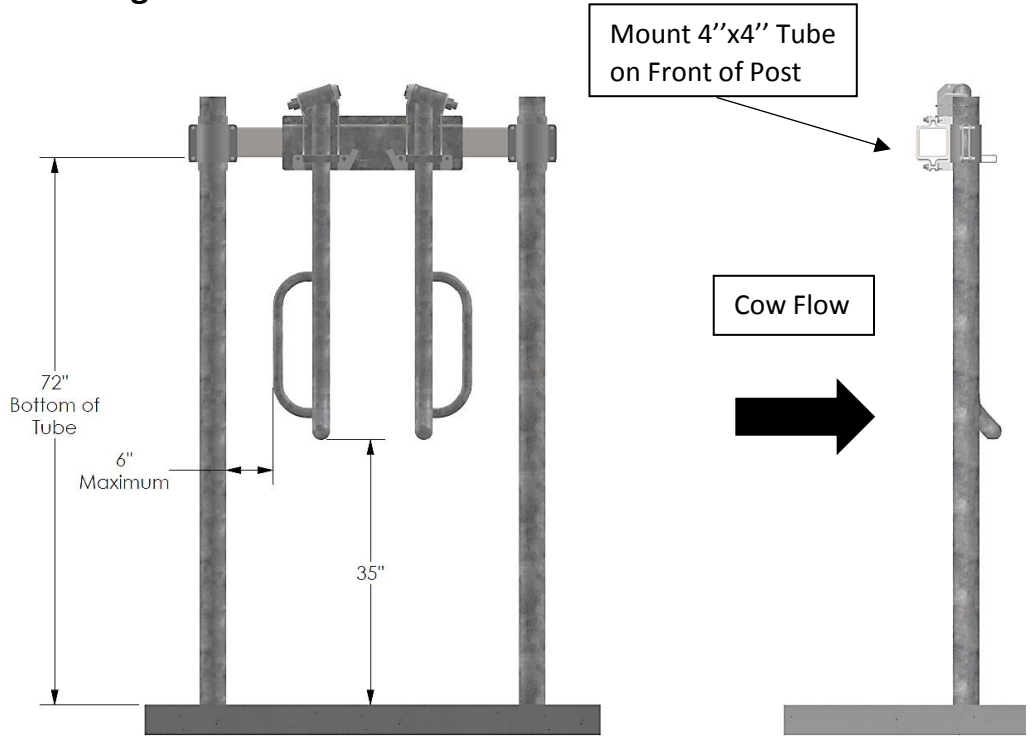

2.0 Wide Exit One Way Gate Operation

Operating Instructions

Lock Position: Rotate the lock in front of the gate tube.

Open Position: Flip the lock into the center between the gate tubes.

Partially Open Training Position: Raise the gate tube approximately half way up until the lock will clear the gate tube and rotate to the lock position. This will hold the gate tube in the partially open position. Use this position to train cows to use the gate.

